

OPERATION AND INSTALLATION

Sealed unvented (pressurised) small water heater

- » SHC 10 AU
- » SHC 15 AU

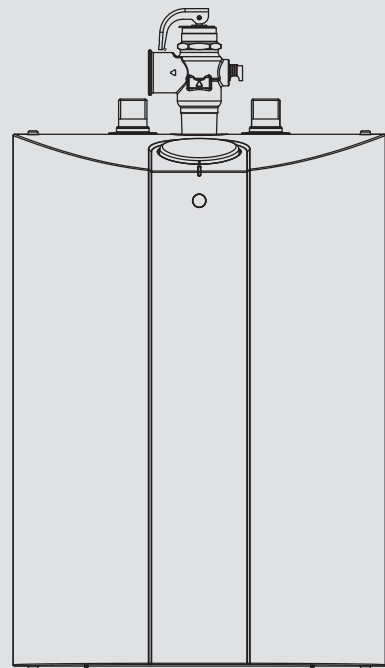

STIEBEL ELTRON

SPECIAL INFORMATION

OPERATION

1. General information	3
1.1 Safety instructions	3
1.2 Other symbols in this documentation	3
1.3 Units of measurement	3
2. Safety	3
2.1 Intended use	3
2.2 General safety instructions	4
2.3 Test symbols	4
3. Appliance description	4
4. Cleaning, care and maintenance	4
5. Troubleshooting	4

INSTALLATION

6. Safety	5
6.1 General safety instructions	5
6.2 Instructions, standards and regulations	5
7. Appliance description	5
7.1 Standard delivery	5
8. Preparations	5
8.1 Installation site	5
9. Installation	6
9.1 Safety valve installation	6
9.2 Appliance installation	6
9.3 Water connection	6
9.4 Power supply	6
10. Commissioning	7
10.1 Initial start-up	7
10.2 Recommissioning	7
11. Shutdown	7
12. Troubleshooting	7
12.1 Activate high limit safety cut-out	7
13. Maintenance	8
13.1 Checking the safety valve	8
13.2 Draining the appliance	8
13.3 Opening the appliance	8
13.4 Removing the flanged immersion heater and temperature controller / high limit safety cut-out	8
13.5 Checking the protective anode and replacing if necessary	8
13.6 Fitting the flanged immersion heater and temperature controller / high limit safety cut-out	9
13.7 Descaling the appliance	9
13.8 Replacing the power cable	9
13.9 Checking the earth conductor	9

14. Specification	10
14.1 Dimensions and connections	10
14.2 Wiring diagram	10
14.3 Heat-up diagram	10
14.4 Country-specific approvals and certifications	10
14.5 Extreme operating and fault conditions	10
14.6 Data table	11

GUARANTEE | ENVIRONMENT AND RECYCLING

SPECIAL INFORMATION

- The appliance may be used by children aged 3 and older and persons with reduced physical, sensory or mental capabilities or a lack of experience and know-how, provided that they are supervised or they have been instructed on how to use the appliance safely and have understood the resulting risks. Children aged 3 to 8 years are only allowed to operate the tap connected to the appliance. Children must never play with the appliance. Children must never clean the appliance or perform user maintenance unless they are supervised.
- When permanently connected to the power supply using a dedicated junction box, the appliance must be able to be isolated from the mains power supply by an isolator that disconnects all poles with at least 3 mm contact separation.
- The power cable may only be replaced (for example if damaged) by a qualified contractor authorised by the manufacturer, using an original spare part.
- Secure the appliance as described in chapter "Installation / Installation".
- Observe the maximum permissible pressure (see chapter "Installation / Specification / Data table").
- Install either a tempering valve or thermostatic mixing valve in all systems intended for personal hygiene.
- Drain the appliance as described in chapter "Installation / Maintenance / Draining the appliance".
- The appliance is pressurised. During the heat-up process, expansion water will drip from the safety valve.

OPERATION

General information

- Regularly activate the safety valve to prevent it from becoming blocked, e.g. by limescale deposits.
- Size the drain pipe so that water can drain off unimpeded when the safety valve is fully opened.
- Fit the drain pipe of the safety valve with a constant downward slope and in a room free from the risk of frost.
- The safety valve drain must remain open to the atmosphere.

OPERATION

1. General information

The chapters "Special Information" and "Operation" are intended for both the user and qualified contractors.

The chapter "Installation" is intended for qualified contractors.



Note

Read these instructions carefully before using the appliance and retain them for future reference. Pass on the instructions to a new user if required.

1.1 Safety instructions

1.1.1 Structure of safety instructions



KEYWORD Type of risk

Here, possible consequences are listed that may result from failure to observe the safety instructions.

► Steps to prevent the risk are listed.

1.1.2 Symbols, type of risk

Symbol	Type of risk
	Injury
	Electrocution
	Burns (burns, scalding)

1.1.3 Keywords

KEYWORD	Meaning
DANGER	Failure to observe this information will result in serious injury or death.
WARNING	Failure to observe this information may result in serious injury or death.
CAUTION	Failure to observe this information may result in non-serious or minor injury.

1.2 Other symbols in this documentation



Note

General information is identified by the adjacent symbol. ► Read these texts carefully.

Symbol	Meaning
	Material losses (appliance damage, consequential losses and environmental pollution)
	Appliance disposal

► This symbol indicates that you have to do something. The action you need to take is described step by step.

1.3 Units of measurement



Note

All measurements are given in mm unless stated otherwise.

2. Safety

2.1 Intended use

This sealed unvented (pressurised) appliance is intended for heating domestic hot water. The appliance can supply one or more draw-off points.

This appliance is intended for domestic use. It can be used safely by untrained persons. The appliance can also be used in a non-domestic environment, e.g. in a small business, as long as it is used in the same way.

Any other use beyond that described shall be deemed inappropriate. Observation of these instructions and of instructions for any accessories used is also part of the correct use of this appliance.

Appliance description

2.2 General safety instructions

DANGER
 Failure to operate the relief valve easing gear at least once every six months may result in the water heater exploding.
 Continuous leakage of water from the valve may indicate a problem with the water heater.

WARNING Burns
 During operation, the tap and safety valve can reach temperatures in excess of 60 °C.
 There is a risk of scalding at outlet temperatures in excess of 43 °C.

WARNING Burns
 The water in the appliance can be heated to temperatures in excess of 60 °C.
 ▶ Install either a tempering valve or thermostatic mixing valve in all systems intended for personal hygiene. With this the delivery temperature for personal hygiene outlets must be limited to 50 °C.

WARNING Injury
 The appliance may be used by children aged 3 and older and persons with reduced physical, sensory or mental capabilities or a lack of experience and know-how, provided that they are supervised or they have been instructed on how to use the appliance safely and have understood the resulting risks. Children aged 3 to 8 years are only allowed to operate the tap connected to the appliance. Children must never play with the appliance. Children must never clean the appliance or perform user maintenance unless they are supervised.

WARNING
 For continued safety of this appliance it must be installed, operated and maintained in accordance with the manufacturer's instructions.

WARNING
 This appliance may deliver water at high temperature. Refer to the plumbing code of Australia (PCA), local requirements and installation instructions to determine if additional delivery temperature control is required.

Material losses
 The user should protect the appliance, the water pipes, the safety valve and the tap against frost.

Material losses
 If the drain pipe of the safety valve is sealed, expanding water can lead to water damage.
 ▶ Never close the drain pipe.

2.3 Test symbols

See type plate on the appliance.

3. Appliance description

The appliance constantly keeps the water content available at the preset temperature. The appliance switches on automatically as soon as its temperature falls below the set value.

Subject to season, varying cold water temperatures can result in different maximum mixed water and outlet volumes.

Note
 The appliance is under mains water pressure. The water volume increases as the cylinder is being heated up. During this process, expansion water drips through the safety valve. This is a necessary and normal process.

4. Cleaning, care and maintenance

- ▶ Never use abrasive or corrosive cleaning agents. A damp cloth is sufficient for cleaning the appliance.
- ▶ Check the taps regularly. Limescale deposits at the tap outlets can be removed using commercially available descaling agents.
- ▶ Regularly activate the safety valve to prevent it from becoming blocked, e.g. by limescale deposits.
- ▶ Have the protective anode checked by a qualified contractor after the first 2 years of operation. The qualified contractor will then determine the intervals at which it must be checked thereafter.

Almost every type of water will deposit limescale at high temperatures. This settles inside the appliance and affects both the performance and service life. The heating element should therefore be descaled if necessary. A qualified contractor who is aware of the local water quality will tell you when the next descaling is due.

5. Troubleshooting

Problem	Cause	Remedy
The appliance does not supply hot water.	No power at the appliance.	Check the plug / fuses in the fuse box.
Water can only be drawn at a reduced rate.	The aerator in the tap is scaled up or dirty.	Descal / replace the aerator.
Loud boiling noises inside the appliance.	The appliance is scaled up.	Have the appliance descaled by a qualified contractor.
Water drips from the safety valve after heat-up.	The safety valve is scaled up or dirty.	Switch the appliance off. Depressurise the appliance by disconnecting it from the power and water supply. Have the safety valve checked by a qualified contractor.
Water drips from the safety valve continuously.	The pressure in the line is above 550 kPa.	Install or readjust pressure reduction valve, set to 550 kPa.

If you cannot remedy the fault, notify your qualified contractor. To facilitate and speed up your enquiry, please provide the serial number from the type plate. (000000):

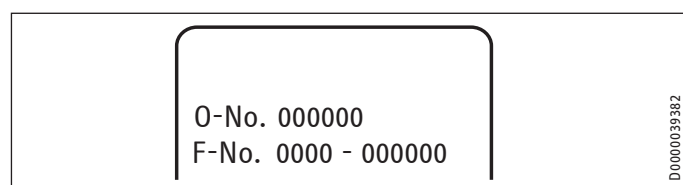

INSTALLATION

6. Safety

Only a qualified contractor should carry out installation, commissioning, maintenance and repair of the appliance.

6.1 General safety instructions

We guarantee trouble-free function and operational reliability only if original accessories and spare parts intended for the appliance are used.

6.2 Instructions, standards and regulations



Note

Observe all applicable national and regional regulations and instructions.



Note

The installation of this appliance shall conform to the Plumbing Code of Australia (PCA), and the New Zealand Building Code.

7. Appliance description

The sealed unvented (pressurised) appliance is only suitable for undersink installation. The appliance is intended for heating cold water and to supply one or several draw-off points.

The appliance may only be installed with pressure taps and in conjunction with the safety valve supplied and a non-return valve in the cold water supply line (see chapter "Installation / Appliance description / Standard delivery").

The safety valve supplied protects the appliance against unacceptable excess pressure. The maximum allowed opening pressure is 700 kPa.

If the water supply pressure exceeds 550 kPa, a pressure reducing valve set to a maximum of 550 kPa, and compliant with AS 1357.2 and installed in accordance with AS 3500.4.2 must be fitted in the installation.

The enamelled internal steel cylinder is equipped with a protective anode. The protective anode protects the inner cylinder against corrosion.

7.1 Standard delivery

The following are delivered with the appliance:

- Wall mounting bracket
- Safety valve G 1/2
- Reducer from R 3/4 male to G 1/2 female

8. Preparations

Water installation

The safety valve supplied and a non-return valve for the cold water supply line are essential.

8.1 Installation site



Material losses

Install the appliance in a room free from the risk of frost.



Material losses

Mount the appliance on the wall. The wall must have a sufficient load-bearing capacity.



Material losses

The appliance is only suitable for undersink installation. The water connections of the appliance point upwards.



Note

Ensure that the appliance is freely accessible for maintenance work.

Always install the appliance vertically and near the draw-off point.

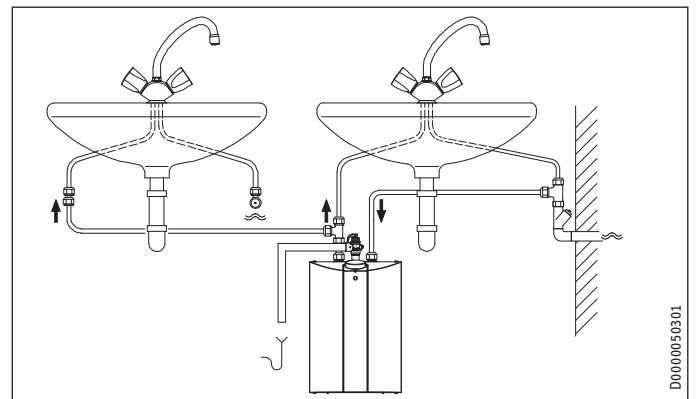

9. Installation

9.1 Safety valve installation

- ▶ Observe local regulations on expansion valves.
- ▶ Observe the safety valve installation instructions.
- ▶ Install a non-return valve in the cold water supply line of the appliance.

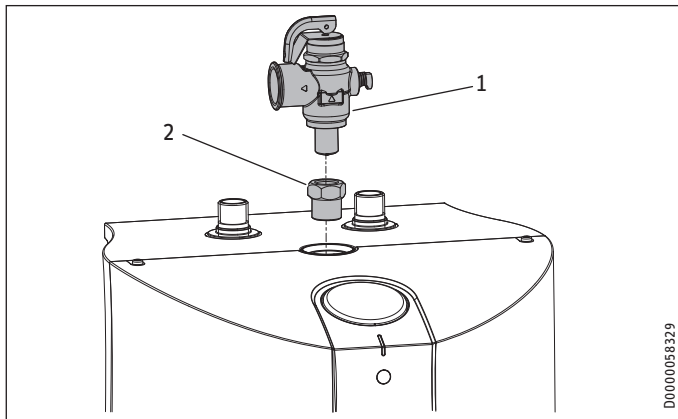

- 1 Safety valve G 1/2
2 Reducer from R 3/4 male to G 1/2 female

- ▶ Fit the safety valve together with the reducer at the top in the centre appliance port.
- ▶ Attach a drain line to the safety valve.
- ▶ Size the drain pipe so that water can drain off unimpeded when the safety valve is fully opened.
- ▶ Fit the drain pipe of the safety valve with a constant downward slope and in a room free from the risk of frost.
- ▶ The safety valve drain must remain open to the atmosphere.
- ▶ Check the safety valve and all fittings for tightness.

9.2 Appliance installation

- ▶ Mark out the holes to be drilled on the wall (see chapter "Installation / Specification / Dimensions and connections").
- ▶ Drill the holes and insert suitable rawl plugs.
- ▶ Secure the wall mounting bracket using suitable screws.
- ▶ Hang the appliance on the wall mounting bracket.



Note
Surplus cable can be stored in the cable compartment.

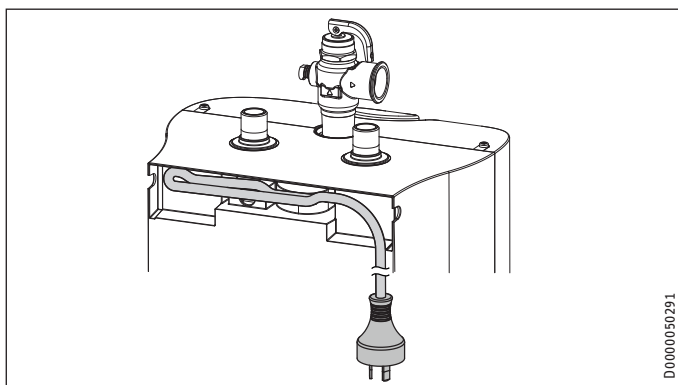

9.3 Water connection



WARNING Burns

The water in the appliance can be heated to temperatures in excess of 60 °C.

- ▶ In Australia and New Zealand observe regulations in accordance with AS/NZS 3500.4.
- ▶ Install either a tempering valve or thermostatic mixing valve in all systems intended for personal hygiene. With this the delivery temperature for personal hygiene outlets must be limited to 50 °C.



Material losses

Carry out all water connection and installation work in accordance with regulations.



Material losses

- ▶ Never interchange the water connections.

- ▶ Observe the maximum permissible pressure (see chapter "Installation / Specification / Data table").

- ▶ Match up the colour coding on the water connections of the appliance to the tap connections:

- R.h. side blue = "Cold water inlet"
- L.h. side red = "DHW outlet"

- ▶ Secure the water connections from the tap to the appliance.

- ▶ Check the entire hydraulic installation for tightness.



Note

Ensure that the water connections are not kinked during installation. Prevent any tensioning during installation.

9.4 Power supply



WARNING ELECTROCUTION

Carry out all electrical connection and installation work in accordance with relevant regulations.



WARNING ELECTROCUTION

When permanently connected to the power supply using a dedicated junction box, the appliance must be able to be isolated from the mains power supply by an isolator that disconnects all poles with at least 3 mm contact separation.



WARNING ELECTROCUTION

Ensure that the appliance is earthed.



Material losses

The voltage specified on the type plate must match the mains voltage.

- ▶ Observe the type plate.

	SHC 10 AU	SHC 15 AU
Connection to a freely accessible standard socket with matching plug	X	X
Permanent connection to an appliance junction box with earth conductor	X	X

INSTALLATION

Commissioning

10. Commissioning



WARNING ELECTROCUTION

Commissioning may only be carried out by a qualified contractor in accordance with safety regulations.

10.1 Initial start-up

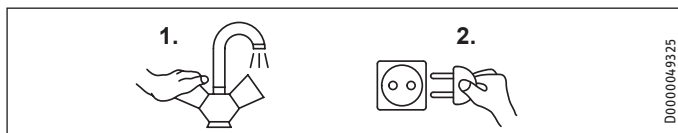

- ▶ Either open the DHW valve of the tap or set the lever mixer tap to "hot" until the water that flows out is free of air bubbles.
- ▶ Insert the plug into the standard socket or set the fuse/MCB in the fuse box.
- ▶ Check the function of the appliance. Ensure that the temperature controller switches off.
- ▶ Check that the safety valve is working correctly.
- ▶ Check the entire hydraulic installation for tightness.



Note

If you fail to follow the correct sequence (first water, then power), the high limit safety cut-out of the water heater will trip.

Proceed as follows:

- ▶ Make the high limit safety cut-out operational by pressing the reset button (see chapter "Installation / Troubleshooting / Activating the high limit safety cut-out").

10.1.1 Appliance handover

- ▶ Explain the functions of the appliance to the user. Show the user how to operate the appliance.
- ▶ Make the user aware of potential dangers, especially the risk of scalding.
- ▶ Hand over these instructions and, if applicable, the instructions for any accessories.

10.2 Recommissioning

See chapter "Installation / Commissioning / Initial start-up".

11. Shutdown

- ▶ Isolate the appliance from the power supply by removing the plug or by tripping the MCB in the fuse box.
- ▶ Drain the appliance (see chapter "Installation / Maintenance / Draining the appliance").

12. Troubleshooting

Fault	Cause	Remedy
The appliance does not supply hot water.	The high limit safety cut-out has tripped.	Remedy the cause of the fault. If necessary, replace the combined temperature controller / high limit safety cut-out. Make the high limit safety cut-out operational by pressing the reset button on the high limit safety cut-out (see chapter "Installation / Troubleshooting / Activating the high limit safety cut-out").
	The controller is faulty.	Replace the combined temperature controller / high limit safety cut-out.
	The flanged immersion heater is faulty.	Replace the flanged immersion heater.
Loud boiling noises inside the appliance.	The appliance is scaled up.	Descale the appliance.
Water drips from the safety valve after heat-up.	The safety valve is scaled up or dirty.	Clean / descale the valve seat.

12.1 Activate high limit safety cut-out

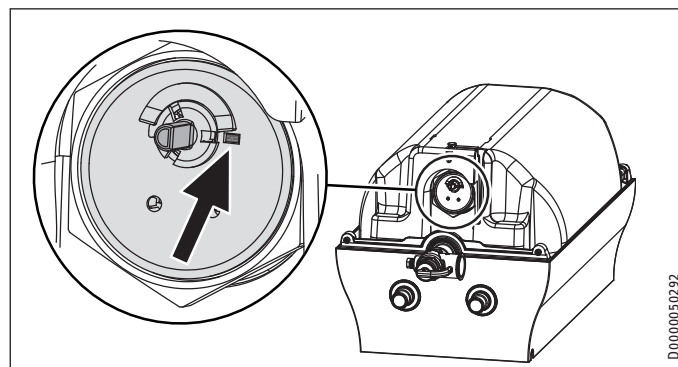

- ▶ Open the appliance (see chapter "Installation / Maintenance / Opening the appliance").
- ▶ Press the reset button on the high limit safety cut-out.
- ▶ Close the appliance cover.

13. Maintenance



WARNING ELECTROCUTION

Before any work on the appliance, disconnect all poles of the appliance from the power supply.

- ▶ Dismantle the appliance for maintenance work.

13.1 Checking the safety valve

- ▶ Check the function of the safety valve regularly.

13.2 Draining the appliance



WARNING Burns

Hot water may escape during the draining process.

- ▶ Drain the appliance via its connectors.

13.3 Opening the appliance

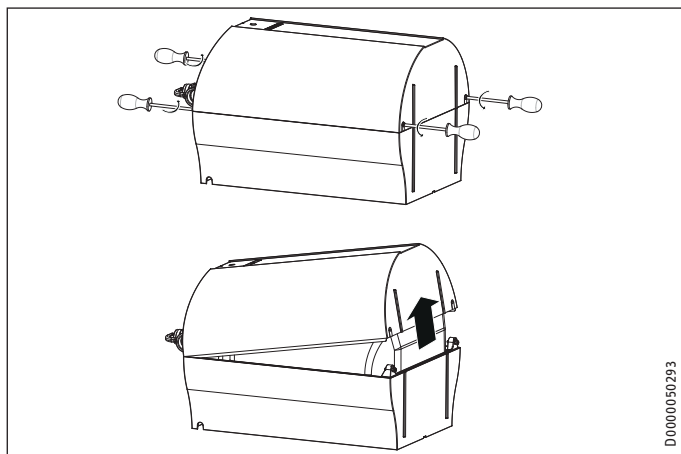

- ▶ Remove the 4 screws from the casing.
- ▶ Open the appliance cover by pivoting the cover upwards and then removing it.
- ▶ Remove the upper insulation semi-shell if required.



Note

The appliance is factory-set to the maximum temperature.

- ▶ Never change the factory-set temperature setting.

13.4 Removing the flanged immersion heater and temperature controller / high limit safety cut-out

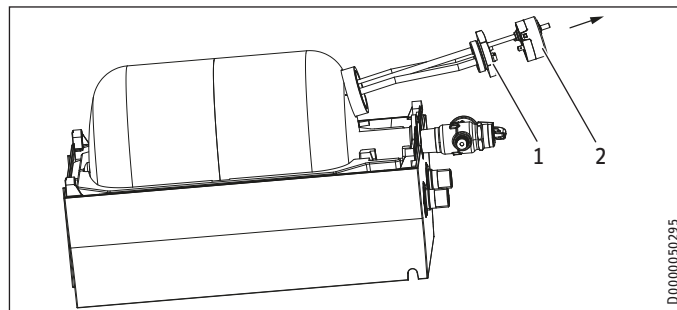

- 1 Flanged immersion heater
 - 2 Combined temperature controller / high limit safety cut-out
- ▶ Disconnect all wires from the combined temperature controller/high limit safety cut-out.
 - ▶ Remove the combined temperature controller / high limit safety cut-out from the flanged immersion heater.
 - ▶ Remove the flanged immersion heater.

13.5 Checking the protective anode and replacing if necessary

Checking the protective anode

- ▶ Check the protective anode for the first time 2 years after installation. This requires removal of the flanged immersion heater. Replace the protective anode if consumed.
- ▶ Decide the intervals in which further checks should be carried out.

INSTALLATION

Maintenance

Replacing the protective anode

- ▶ Hold the protective anode with pliers.

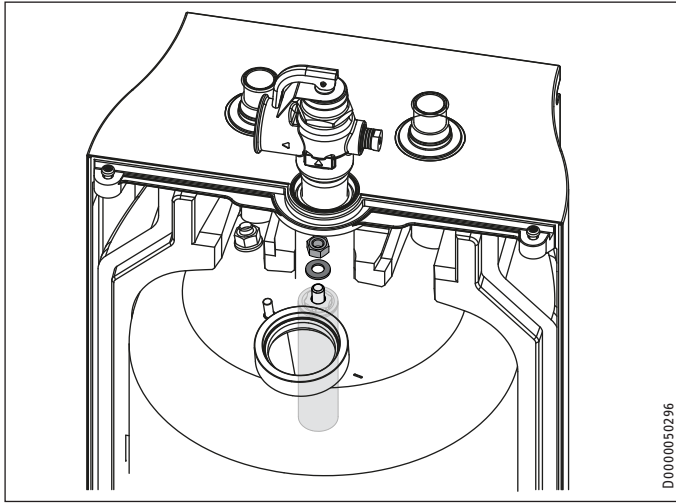

- ▶ Undo the nut.

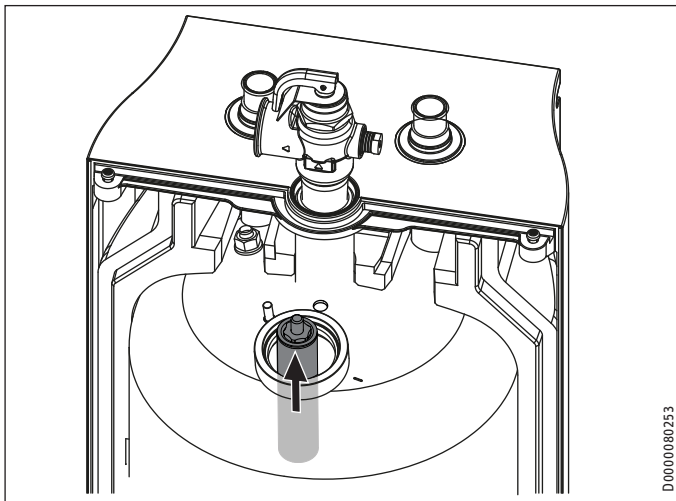

- ▶ Remove the protective anode through the aperture in the flanged immersion heater.
- ▶ Insert a new protective anode with gasket and support ring into the tank aperture.
- ▶ Secure the protective anode with a contact washer and nut to a torque of 11 ± 1.2 Nm.

13.6 Fitting the flanged immersion heater and temperature controller / high limit safety cut-out

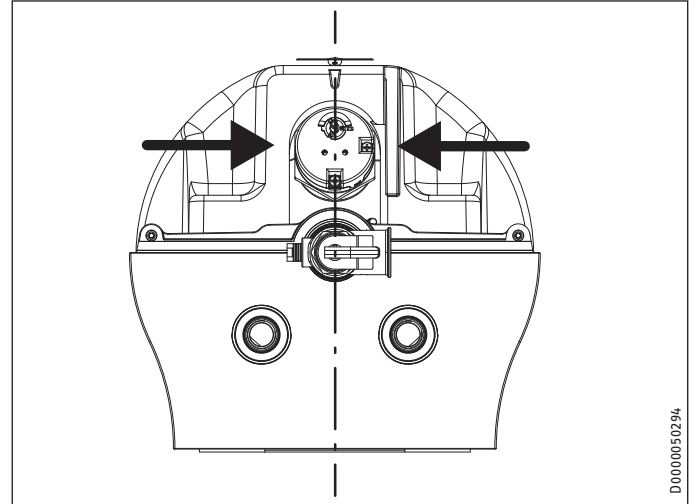

- ▶ Insert the flanged immersion heater into the cylinder aperture well as far as it will go.
- ▶ Push the combined temperature controller / high limit safety cut-out into the flanged immersion heater as far as it will go.
- ▶ Align the flanged immersion heater and the combined temperature controller / high limit safety cut-out in accordance with the diagram.
- ▶ Turn the shaft of the temperature controller anti-clockwise as far as it will go.
- ▶ Reconnect all wires in their original positions on the combined temperature controller/high limit safety cut-out.

13.7 Descaling the appliance



Material losses

Never treat the protective anode with descaling agents.

- ▶ Remove the flanged immersion heater.
- ▶ Carefully tap the heating element to remove coarse limescale deposits.
- ▶ Immerse the heating element up to the flange plate in descaling agent.

13.8 Replacing the power cable

The power cable must only be replaced by a qualified contractor with an original spare part.

13.9 Checking the earth conductor

- ▶ Check the earth conductor across a water connector and the earth conductor contact of the power cable.

14. Specification

14.1 Dimensions and connections

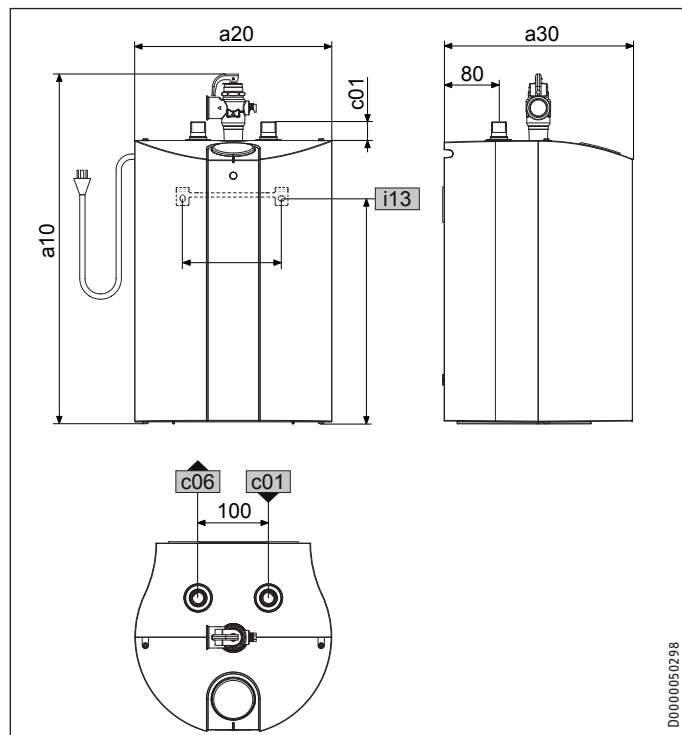

D0000050298

			SHC 10 AU	SHC 15 AU	
a10	Appliance	Height	mm	498	523
a20	Appliance	Width	mm	280	320
a30	Appliance	Depth	mm	270	318
c01	Cold water Inlet	Male thread		G 1/2 A	G 1/2 A
		Top clearance	mm	26.5	23
c06	DHW outlet	Male thread		G 1/2 A	G 1/2 A
i13	Wall mounting bracket	Height	mm	320	342
		Horizontal hole spacing	mm	140	200

14.2 Wiring diagram

1/N/PE ~ 220-240 V

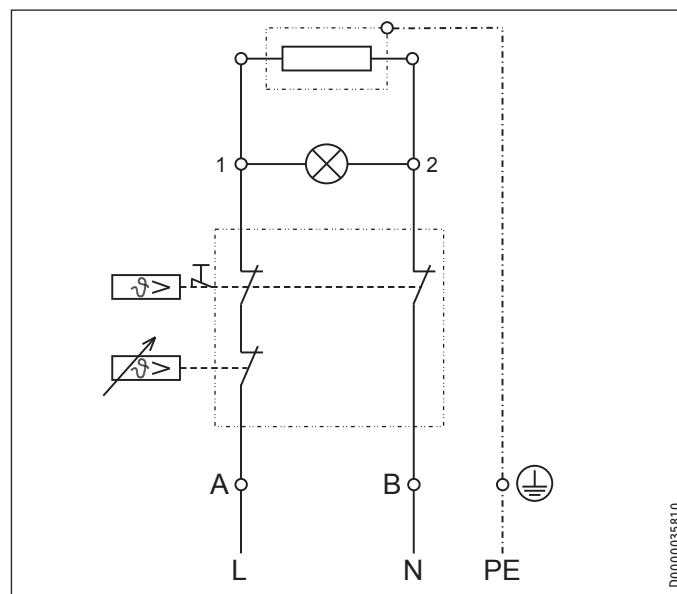

D0000035810

14.3 Heat-up diagram

The heat-up period depends on the degree of scaling and residual heat. For the heat-up time for a cold water supply at 10 °C and a maximum temperature setting, see the diagram.

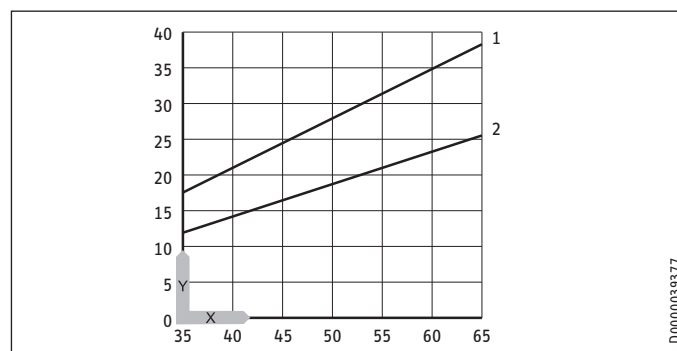

D0000039377

x Temperature in °C

y Duration in min

1 15 l appliance

2 10 l appliance

14.4 Country-specific approvals and certifications

The test symbols can be seen on the type plate.

14.5 Extreme operating and fault conditions

In the case of faults, a peak temperature of up to 99 °C may briefly occur in the system.

INSTALLATION

Specification

14.6 Data table

		SHC 10 AU			SHC 15 AU		
		235002			235001		
Hydraulic data							
Nominal capacity	l	10			15		
Mixed water volume at 40 °C (IEC 60379)	l	15.3			23		
Electrical data							
Rated voltage	V	220	230	240	220	230	240
Rated output	kW	1.4	1.5	1.6	1.4	1.5	1.6
Rated current	A	6.2	6.5	6.8	6.2	6.5	6.8
MCB/fuse rating	A	10	10	10	10	10	10
Phases		1/N/PE			1/N/PE		
Frequency	Hz	50/60			50/60		
Application limits							
Max. permissible pressure	MPa	0.7			0.7		
Min. water inlet pressure	MPa	0.1			0.1		
Max. water inlet pressure	MPa	0.6			0.6		
Max. flow rate	l/min	10			10		
Energy data							
Standby energy consumption/24 h at 65 °C	kWh	0.5			0.53		
Versions							
IP rating		IP24 D			IP24 D		
Type of installation		Undersink			Undersink		
Type		Pressurised			Pressurised		
Internal cylinder material		Steel, enamelled			Steel, enamelled		
Thermal insulation material		Polystyrene			Polystyrene		
Casing material		Plastic			Plastic		
Colour		White			White		
Dimensions							
Depth	mm	270			318		
Height	mm	498			523		
Width	mm	280			320		
Weights							
Weight	kg	7.2			9.0		

Guarantee

The guarantee conditions of our German companies do not apply to appliances acquired outside of Germany. In countries where our subsidiaries sell our products a guarantee can only be issued by those subsidiaries. Such guarantee is only granted if the subsidiary has issued its own terms of guarantee. No other guarantee will be granted.

We shall not provide any guarantee for appliances acquired in countries where we have no subsidiary to sell our products. This will not affect warranties issued by any importers.

Environment and recycling

We would ask you to help protect the environment. After use, dispose of the various materials in accordance with national regulations.

Stiebel Eltron Warranty for Water Heaters – Models SHC 10 AU and SHC 15 AU

Who gives the warranty

1. The warranty is given by Stiebel Eltron (Aust) Pty Ltd (A.B.N. 82 066 271 083) of 294 Salmon Street, Port Melbourne, Victoria, 3207 (“we”, “us” or “our”).

The warranty

2. This warranty applies to Stiebel Eltron Water Heaters – Models SHC 10 AU and SHC 15 AU (the “unit”) manufactured after 1 June 2013.
3. Subject to the warranty exclusions we will repair or replace, at our absolute discretion, a faulty component in your unit free of charge if it fails to operate in accordance with its specifications during the warranty period.
4. If we repair or replace a faulty component to your unit under this warranty, the warranty period is not extended from the time of the repair or replacement.
5. The warranty period commences on the date of completion of the installation of the unit. Where the date of completion of installation is not known, then the warranty period will commence 2 months after the date of manufacture.
6. The warranty period for a unit used for domestic purposes is shown in the table below. Domestic purposes means that the unit is used in a domestic dwelling.

Component	Warranty period
All components, excluding PTR valve	5 years from the date of completion of the installation of the unit.

7. The warranty period for a unit used for commercial purposes is shown in the table below. Commercial purposes means that the unit is used for a non-domestic purpose and includes but not limited to being used in a motel, hotel, mining camp or nursing home.

Component	Warranty period
All components, excluding PTR valve	1 year from the date of completion of the installation of the unit.

Your entitlement to make a warranty claim

8. You are entitled to make a warranty claim if:
 - 8.1. you own the unit or if you have the owner’s consent to represent the owner of the unit;
 - 8.2. you contact us within a reasonable time of discovering the problem with the unit;

How you make a warranty claim

9. To make a warranty claim you must provide us with the following information:

- 9.1. The model number of the unit;
- 9.2. A description of the problem with the unit;
- 9.3. The name, address and contact details (such as phone number and e-mail address) of the owner;
- 9.4. The address where the unit is installed and the location (e.g. in laundry);
- 9.5. The serial number of the unit;
- 9.6. The date of purchase of the unit and the name of the seller of the unit;
- 9.7. The date of installation of the unit;
- 9.8. A copy of the certificate of compliance when the unit was installed.
- 10. The contact details for you to make your warranty claim are:

Name:	Stiebel Eltron (Aust) Pty Ltd
Address:	294 Salmon Street, Port Melbourne, Victoria, 3207
Telephone:	1800 153 351 (8.00 am to 5.00 pm AEST Monday to Friday)
Contact person:	Customer Service Representative
E-mail:	service@stiebel-eltron.com.au
- 11. We will arrange a suitable time with you to inspect and test the unit.
- e) connection to faulty equipment, such as damaged valves;
- f) foreign matter in the water supply, such as sludge or sediment;
- g) corrosive elements in the water supply;
- h) accidental damage;
- i) act of God, including damage by flood, storm, fire, lightning strike and the like;
- j) excessive water pressure, negative water pressure (partial vacuum) or water pressure pulsation;
- k) ingress of vermin.
- 12.6. The unit was damaged before it was installed e.g. it was damaged in transit.
- 12.7. An unauthorised person has modified, serviced, repaired or attempted to repair the unit without our consent.
- 12.8. Non genuine parts other than those manufactured or approved by us have been used on the unit.
- 13. We may charge you:
 - 13.1. for any additional transport costs if the unit is installed more than 30 kilometres from our closest authorised service technician.
 - 13.2. for the extra time it takes our authorised service technician to access the unit for inspection and testing if it is not sited in accordance with the Operating and Installation Guide and not readily accessible for inspection.
 - 13.3. for any extra costs of our authorised service technician to make the unit safe for inspection.
- 14. You must ensure that access to the unit by our authorised service technician is safe and free from obstruction.
- 15. Our authorised service technician may refuse to inspect and test the unit until you provide safe and free access to it, at your cost.
- 16. If we reject your warranty claim in accordance with clause 12, we may charge you for our authorised service technician's labour costs to inspect and test the unit.
- 17. In order to properly test the unit we may remove it to another location for testing.

Warranty exclusions

- 12. We may reject your warranty claim if:
 - 12.1. The unit was not installed by registered and qualified tradespeople.
 - 12.2. The unit was not installed and commissioned:
 - a) in Australia;
 - b) in accordance with the Operating and Installation Guide; and
 - c) in accordance with the relevant statutory and local requirements of the State or Territory in which the unit is installed.
 - 12.3. The unit has not been operated or maintained in accordance with the Operating and Installation Guide.
 - 12.4. The unit does not bear its original Serial Number or Rating Label.
 - 12.5. The unit was damaged by any or any combination of the following:
 - a) normal fair wear and tear;
 - b) connection to an incorrect water supply;
 - c) connection to water from a bore, dam or swimming pool;
 - d) connection to an incorrect power supply;
- 18. Our goods come with guarantees that cannot be excluded under the Australian Consumer Law. You are entitled to a replacement or refund for a major failure and compensation for any other reasonably foreseeable loss or damage. You are also entitled to have the goods repaired or replaced if the goods fail to be of acceptable quality and the failure does not amount to a major failure.
- 19. The Stiebel Eltron warranty for the unit is in addition to any rights and remedies you may have under the Australian Consumer Law.

NOTES

NOTES

Deutschland

STIEBEL ELTRON GmbH & Co. KG
Dr.-Stiebel-Straße 33 | 37603 Holzminden
Tel. 05531 702-0 | Fax 05531 702-480
info@stiebel-eltron.de
www.stiebel-eltron.de

Verkauf

Tel. 05531 702-110 | Fax 05531 702-95108 | info-center@stiebel-eltron.de

Kundendienst

Tel. 05531 702-111 | Fax 05531 702-95890 | kundendienst@stiebel-eltron.de

Ersatzteilverkauf

Tel. 05531 702-120 | Fax 05531 702-95335 | ersatzteile@stiebel-eltron.de

Australia

STIEBEL ELTRON Australia Pty. Ltd.
294 Salmon Street | Port Melbourne VIC 3207
Tel. 03 9645-1833 | Fax 03 9644-5091
info@stiebel-eltron.com.au
www.stiebel-eltron.com.au

Austria

STIEBEL ELTRON Ges.m.b.H.
Gewerbegebiet Neubau-Nord
Margaritenstraße 4 A | 4063 Hörsching
Tel. 07221 74600-0 | Fax 07221 74600-42
info@stiebel-eltron.at
www.stiebel-eltron.at

Belgium

STIEBEL ELTRON bvba/sprl
't Hofveld 6 - D1 | 1702 Groot-Bijgaarden
Tel. 02 42322-22 | Fax 02 42322-12
info@stiebel-eltron.be
www.stiebel-eltron.be

China

STIEBEL ELTRON (Tianjin) Electric Appliance
Co., Ltd.
Plant C3, XEDA International Industry City
Xiqing Economic Development Area
300385 Tianjin
Tel. 022 8396 2077 | Fax 022 8396 2075
info@stiebel-eltron.cn
www.stiebel-eltron.cn

Czech Republic

STIEBEL ELTRON spol. s r.o.
Dopraváků 749/3 | 184 00 Praha 8
Tel. 251116-111 | Fax 235512-122
info@stiebel-eltron.cz
www.stiebel-eltron.cz

Finland

STIEBEL ELTRON OY
Kapinakuja 1 | 04600 Mäntsälä
Tel. 020 720-9988
info@stiebel-eltron.fi
www.stiebel-eltron.fi

France

STIEBEL ELTRON SAS
7-9, rue des Selliers
B.P 85107 | 57073 Metz-Cédex 3
Tel. 0387 7438-88 | Fax 0387 7468-26
info@stiebel-eltron.fr
www.stiebel-eltron.fr

Hungary

STIEBEL ELTRON Kft.
Gyár u. 2 | 2040 Budaörs
Tel. 01 250-6055 | Fax 01 368-8097
info@stiebel-eltron.hu
www.stiebel-eltron.hu

Japan

NIHON STIEBEL Co. Ltd.
Kowa Kawasaki Nishiguchi Building 8F
66-2 Horikawa-Cho
Saiwai-Ku | 212-0013 Kawasaki
Tel. 044 540-3200 | Fax 044 540-3210
info@nihonstiebel.co.jp
www.nihonstiebel.co.jp

Netherlands

STIEBEL ELTRON Nederland B.V.
Daviotenweg 36 | 5222 BH 's-Hertogenbosch
Tel. 073 623-0000 | Fax 073 623-1141
info@stiebel-eltron.nl
www.stiebel-eltron.nl

New Zealand

Stiebel Eltron NZ Limited
61 Barrys Point Road | Auckland 0622
Tel. +64 9486 2221
info@stiebel-eltron.co.nz
www.stiebel-eltron.co.nz

Poland

STIEBEL ELTRON Polska Sp. z O.O.
ul. Działkowa 2 | 02-234 Warszawa
Tel. 022 60920-30 | Fax 022 60920-29
biuro@stiebel-eltron.pl
www.stiebel-eltron.pl

Russia

STIEBEL ELTRON LLC RUSSIA
Urzhumskaya street 4,
building 2 | 129343 Moscow
Tel. +7 495 125 0 125
info@stiebel-eltron.ru
www.stiebel-eltron.ru

Slovakia

STIEBEL ELTRON Slovakia, s.r.o.
Hlavná 1 | 058 01 Poprad
Tel. 052 7127-125 | Fax 052 7127-148
info@stiebel-eltron.sk
www.stiebel-eltron.sk

Switzerland

STIEBEL ELTRON AG
Industrie West
Gass 8 | 5242 Lupfig
Tel. 056 4640-500 | Fax 056 4640-501
info@stiebel-eltron.ch
www.stiebel-eltron.ch

Thailand

STIEBEL ELTRON Asia Ltd.
469 Moo 2 Tambol Klong-Jik
Amphur Bangpa-In | 13160 Ayutthaya
Tel. 035 220088 | Fax 035 221188
info@stiebel-eltronasia.com
www.stiebel-eltronasia.com

United Kingdom and Ireland

STIEBEL ELTRON UK Ltd.
Unit 12 Stadium Court
Stadium Road | CH62 3RP Bromborough
Tel. 0151 346-2300 | Fax 0151 334-2913
info@stiebel-eltron.co.uk
www.stiebel-eltron.co.uk

United States of America

STIEBEL ELTRON, Inc.
17 West Street | 01088 West Hatfield MA
Tel. 0413 247-3380 | Fax 0413 247-3369
info@stiebel-eltron-usa.com
www.stiebel-eltron-usa.com



Irrtum und technische Änderungen vorbehalten! | Subject to errors and technical changes! | Sous réserve d'erreurs et de modifications techniques! | Onder voorbehoud van vergissingen en technische wijzigingen! | Salvo error o modificación técnica! | Excepto erro ou alteração técnica | Zastrzeżone zmiany techniczne i ewentualne błędy | Omyly a technické změny jsou vyhrazeny! | A muszaki változtatások és tévedések jogát fenntartjuk! | Отсутствие ошибок не гарантируется. Возможны технические изменения. | Chyby a technické zmeny sú vyhradené! | Stand 9646

STIEBEL ELTRON